

DC/DC Wide Input Converter ECW 200 Watt Series



DC/DC converter module with input to output isolation of 1500 VDC • Pi-filter at input • Continuous short circuit proof • High efficiency • Low output ripple and noise • Low silhouette • Aluminum base with plastic case • External output voltage adjust • Inhibit on/off control • Full brick case

DC/DC Konverter-Modul mit galvanischer Trennung Eingang / Ausgang von 1500 VDC • Pi-Filter am Eingang • Dauerkurzschlussfest • Hoher Wirkungsgrad • Gute Werte von Rippel und Noise • Geringe Bauhöhe • Aluminium Grundplatte mit Kunststoffgehäuse • Externer Ausgangsspannungsabgleich • Inhibit • Full brick Gehäuse

Module convertisseur CC/CC avec séparation galvanique entrée/sortie 1500 VDC • Filtre en Pi à l'entrée • Protection courts-circuits permanente • Rendement élevé • Ondulation résiduelle de sortie très faible • Profile bas • Base en aluminium, boîtier en plastique • Ajustement externe de la tension de sortie • Inhibit • Full brick boîtier

Product range

Typenübersicht

Sommaire des types

Model	Input nominal	Input range	Input current		Output Uout	Output Iout max.	Operating temperature	Efficiency typ.
			max. @ full load	No Load				
ECW48-2V5200	48 VDC	36...72 VDC	2800 mA	25 mA	2.5 VDC	40.00 A	For all models:	74%
ECW48-3V3200	48 VDC	36...72 VDC	3500 mA	25 mA	3.3 VDC	40.00 A	-40...+100°C	79%
ECW48-5V1200	48 VDC	36...72 VDC	5000 mA	25 mA	5.1 VDC	40.00 A	case temperature	83%
ECW48-12200	48 VDC	36...72 VDC	5000 mA	25 mA	12.0 VDC	17.00 A	see derating	85%
ECW48-15200	48 VDC	36...72 VDC	5000 mA	25 mA	15.0 VDC	13.30 A	specification	85%
ECW48-24200	48 VDC	36...72 VDC	5000 mA	25 mA	24.0 VDC	8.40 A	on page 4	85%
ECW48-48200	48 VDC	36...72 VDC	5000 mA	25 mA	48.0 VDC	4.20 A		85%

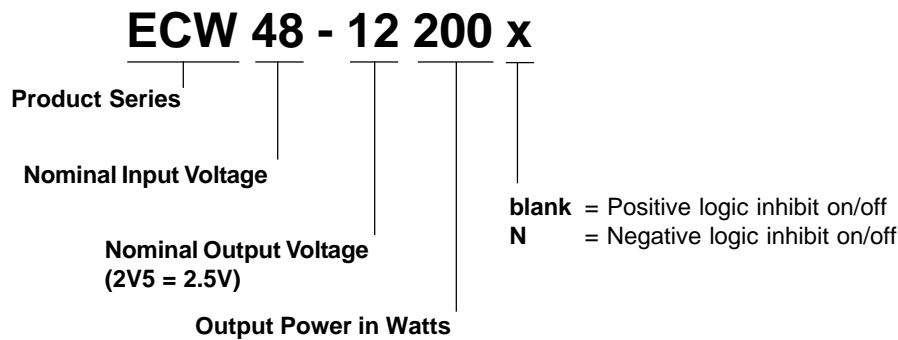

Specifications

Spezifikationen

Spécifications

All values refer to an ambient temperature of 25°C and nominal rated values where nothing else is specified

Output voltage accuracy	Ausgangsspannungsgenauigkeit	Précision de la tension de sortie	±1% of Uout nom.
Ext. output voltage adjustment	Ext. Ausgangsspannungsabgleich	Ajustement ext. de la tension de sortie	-15% to +10%
Transient Response	Sprungcharakteristik	Réponse en transitoires	25% step load change < 500u sec.
Residual output ripple and noise [BW 20 MHz]	Ausgangsspannungsrippel und Noise [BW 20 MHz]	Ondulation résiduelle et bruit de sortie [BW 20 MHz]	3.3/5.1V 40mV RMS, max. 100mVpp, max. 12/15V 60mV RMS, max. 150mVpp, max. 24V 100mV RMS, max. 240mVpp, max. 48V 200mV RMS, max. 480mVpp, max.
Short circuit protection	Kurzschlussfestigkeit	Protection courts-circuits	continuous
Line regulation (Umax...Umin)	Leistungsregulierung (Umax...Umin)	Régulation ligne (Umax...Umin)	±0.2% max. @ Iout nom.
Load regulation (100...0%)	Lastregulierung (100...0%)	Régulation charge (100...0%)	±0.2% max.
Isolation voltage	Isolationsspannung	Tension d'isolement	Input/Output 1500VDC Input/Case 1500VDC Output/Case 1500VDC
Isolation resistance	Isolationswiderstand	Résistance d'isolement	> 10 MOhm
Switching frequency	Schaltfrequenz	Fréquence de découpage	typ. 400 kHz
MTBF (MIL-HB 217E at 25°C)	MTBF (MIL-HB 217E bei 25°C)	MTBF (MIL-HB 217E à 25°C)	>1'000'000 hrs.
EMC Conducted and radiated	EMV Leitungsgebunden und abgestrahlt	EMC Emis et conduit	EN55022/11 Class A with external input capacitor
Temperature coefficient	Temperaturkoeffizient	Coefficient de température	typ. ±0.03%/K
Storage temperature	Lagertemperatur	Température de stockage	-40...+105°C
Thermal shutdown range	Thermische Abschaltung	Coupe thermique	Tcase 100°C
Current Limit	Strombegrenzung	Limitation du courant	110...140% Nominal output
Over voltage protection	Überspannungsschutz	Protection contre surtension	115...140% Vo nom.
Undervoltage lockout	Unterspannungsverhalten	Bloquage de sous-tension	power up @ 34V power down @ 32.5V
Case material	Gehäusematerial	Matériaux du boîtier	Aluminium base with plastic case
Soldering information	Lötinformationen	Information de soudage	275°C for 10 sec.

Specifications

Spezifikationen

Spécifications

All values refer to an ambient temperature of 25°C and nominal rated values where nothing else is specified

Soldering information

Lötinformationen

Information de soudage

270°C for 10sec.

Weight

Gewicht

Poids

approx. 190g

EMC information

EMV Informationen

Information CEM

EMC information ECW48-12200 EN55022/11 Class A

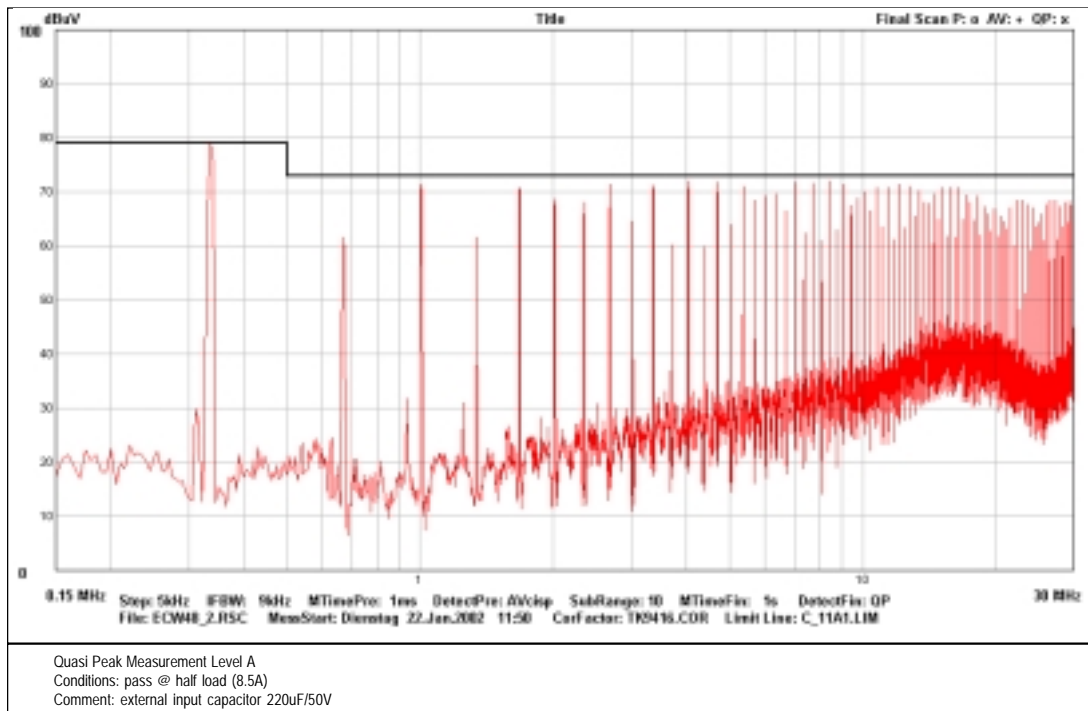

Inhibit on/off control

The ECW 200 allows the user to switch the module on and off electronically by inhibit on/off feature. The converters are available in "positive logic" or "negative logic" (option) versions for inhibit on/off.

Logic table

Logic state (Pin 2)	Negative logic*	Positive logic
Logic low	Module on	Module off
Logic high	Module off	Module on

Application example

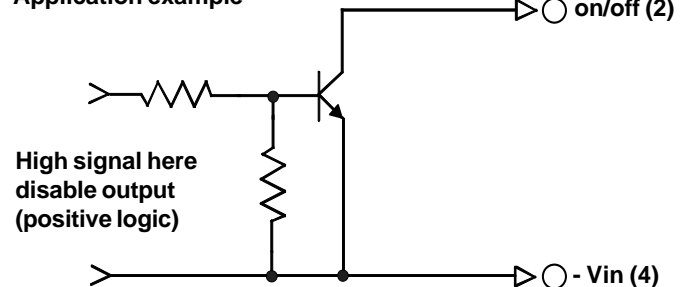

* Suffix "N" to the model number with active low inhibit on /off

Derating ECW 200 Watt Series

The operating case temperature range of ECW 200 series is -40°C to +100°C. When operating the ECW 200 series, proper derating or cooling is needed. The following curves are the derating curves of ECW 200 without and with heat sink. Please note that these are relative values in a test environment. Ambient temperature can not be exactly defined in an application, only the case temperature.

Without Heat Sink: Power Dissipated vs Ambient Temperature and Air Flow

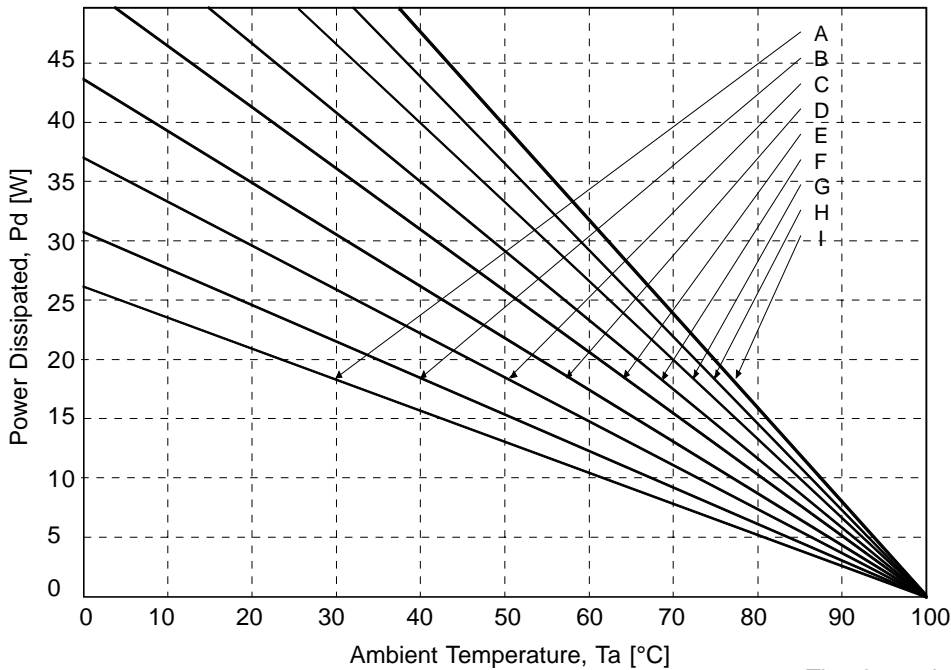

- A : Natural Convection 0.1m/s
- B : 0.5m/s
- C : 1.0m/s
- D : 1.5m/s
- E : 2.0m/s
- F : 2.5m/s
- G : 3.0m/s
- H : 3.5m/s
- I : 4.0m/s

Where:

The Power Dissipation (Pd):

$$Pd = Pi - Po = Po * (1 - \eta) / \eta$$

The temperature rise (delta T):

$$\Delta T = Pd * Rca$$

The thermal resistances without heat sink are listed below:

air flow rate	typical Rca
natural convection 0.1m/s	3.82 K/W
0.5m/s	3.23 K/W
1.0m/s	2.71 K/W
1.5m/s	2.28 K/W
2.0m/s	1.92 K/W
2.5m/s	1.68 K/W
3.0m/s	1.50 K/W
3.5m/s	1.35 K/W
4.0m/s	1.23 K/W

With Heat Sink FH-61117-13: Power Dissipated vs Ambient Temperature; Height: 12.7mm

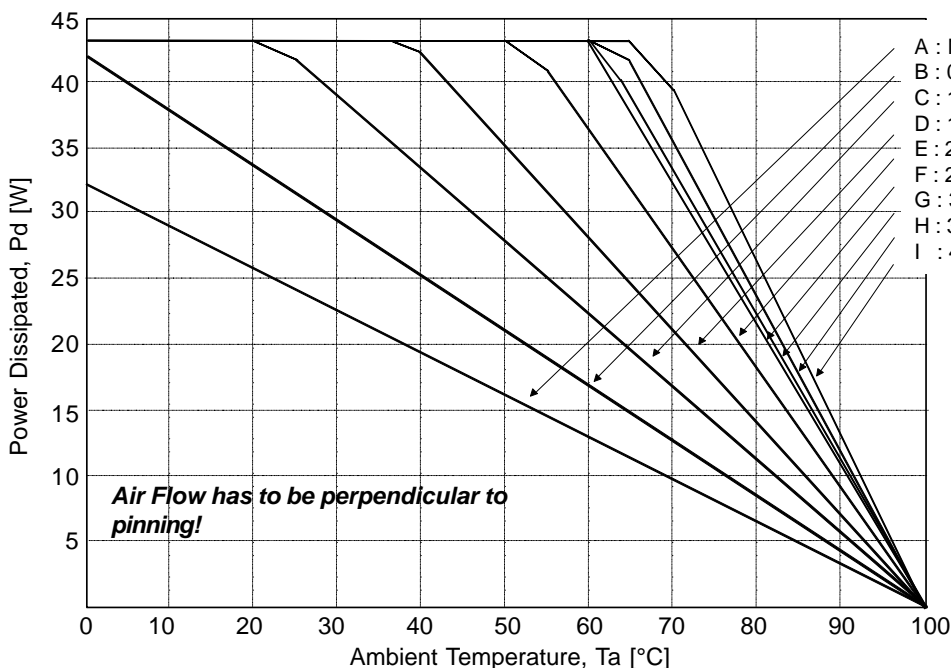

- A : Natural Convection 0.1m/s
- B : 0.5m/s
- C : 1.0m/s
- D : 1.5m/s
- E : 2.0m/s
- F : 2.5m/s
- G : 3.0m/s
- H : 3.5m/s
- I : 4.0m/s

Remark:

Fabrimex recommends a free space of at least half the height of the heat sink above the heat sink at natural air flow. For the FH-61117-13 this equals to:

Free space = 7.4 mm min.

The typical thermal resistances with heat sink FH-61117-13 are as follows:

air flow rate	typical Rca
natural convection 0.1m/s	3.12 K/W
0.5m/s	2.35 K/W
1.0m/s	1.77 K/W
1.5m/s	1.38 K/W
2.0m/s	1.10 K/W
2.5m/s	0.91 K/W
3.0m/s	0.88 K/W
3.5m/s	0.82 K/W
4.0m/s	0.77 K/W

With Heat Sink FH-61117-25: Power Dissipated vs Ambient Temperature; Height: 25.4 mm

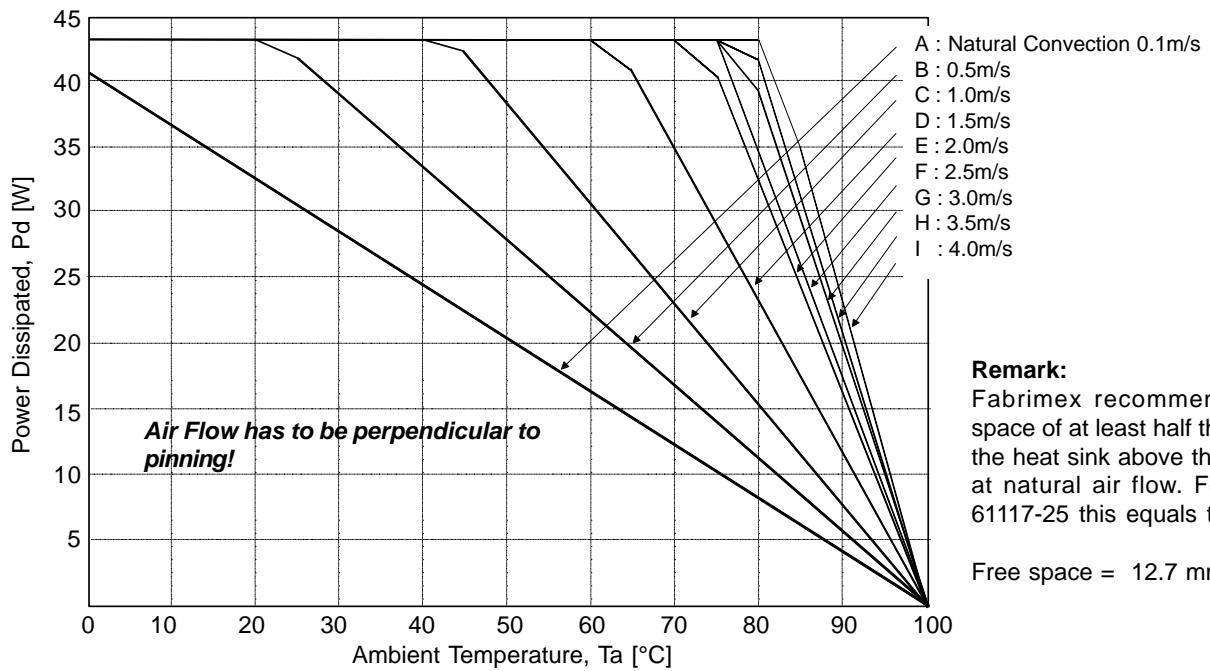

The typical thermal resistances with heat sink FH-61117-25 are as follows:

air flow rate	typical Rca
natural convection 0.1m/s	2.44 K/W
0.5m/s	1.75 K/W
1.0m/s	1.27 K/W
1.5m/s	0.85 K/W
2.0m/s	0.62 K/W
2.5m/s	0.55 K/W
3.0m/s	0.51 K/W
3.5m/s	0.47 K/W
4.0m/s	0.43 K/W

External output trim

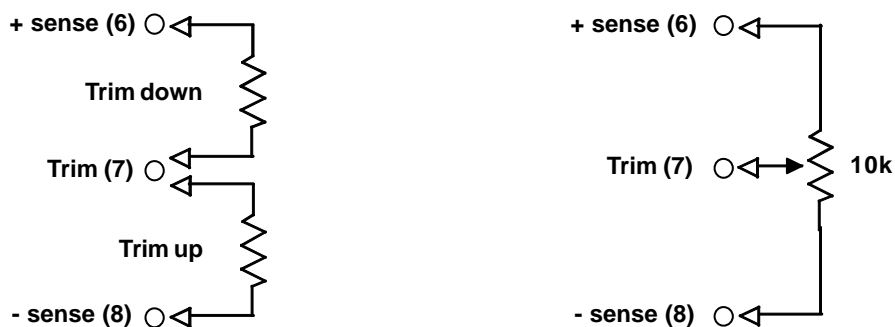

View from bottom; Normal tolerance 1/10 ±0.5 mm, 1/100 ±0.25 mm; Pin tolerance ±0.5 mm diameter

FULL BRICK CASE

Mounting Inserts
M3 x 0,5 trough

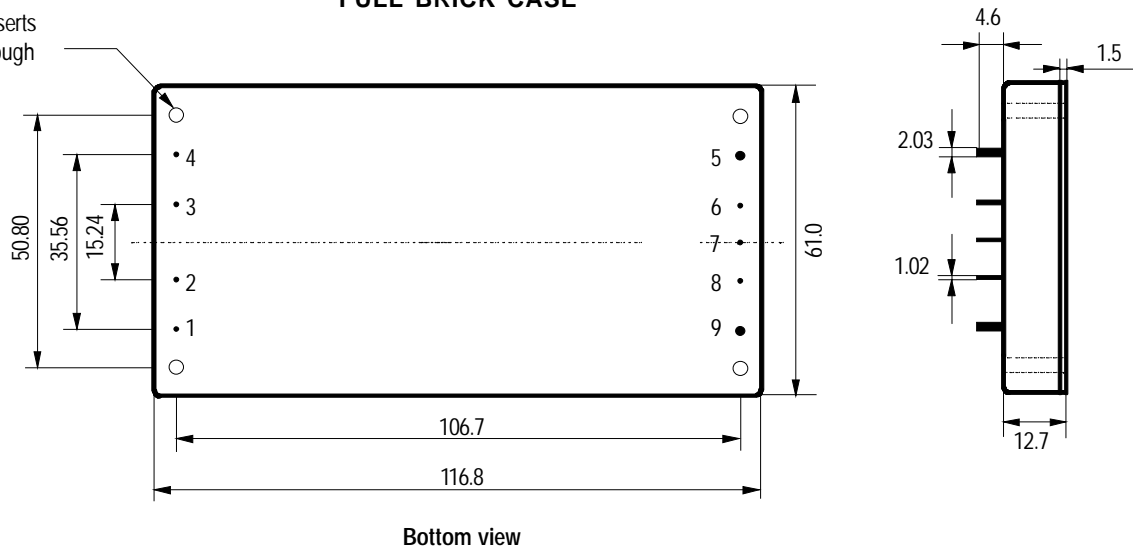

Pin	Function
1	+ Vin
2	on/off
3	case
4	- Vin
5	- Vout
6	- sense
7	trim
8	+ sense
9	+ Vout

Cleaning

Waschen

Lavage

The modules are cleanable with the today's known and in the electronics industry usually used products.

Due to the different cleaning processes and new available products, we highly recommend to do a compatibility test when using the converters the first time.

Die Module sind waschbar mit den heute bekannten und in der Elektronikindustrie üblichen Reinigungsmitteln.

Bedingt durch die verschiedenen Reinigungsprozesse und neu auf den Markt kommende Mittel, raten wir dringend beim Ersteinsatz der Konverter eine Verträglichkeitsprüfung vorzunehmen.

Les modules sont lavables avec les solvants couramment utilisés dans l'industrie électronique.

Dû aux différents processus de lavage et aux nouveaux détergents disponibles sur le marché, il est strictement recommandé de faire un test de compatibilité avant la première utilisation.

Notice: All statements, technical information, and recommendations related to FABRIMEX's products are based on information believed to be reliable, but the accuracy or completeness thereof is not guaranteed. Before utilizing the product, the user should determine the suitability of the product for its intended use.

Switzerland:
FABRIMEX AG • Industriestrasse 4B • Volketswil
Post Address: P.O.Box • CH-8603 Schwerzenbach
Tel: +41-44-908 13 40 • Fax: +41-44-908 13 00
Internet: <http://www.fabrimex.com>

FABRIMEX
POWER SUPPLIES

Germany:
CAC FABRIMEX GmbH • D-89543 Gerstetten
Tel: 07323/ 950-0 • Fax: 07323/ 95050