

DC/DC Power-On-Point (POP[®]) Regulator ERS 10 Ampere SIL/SMD Series

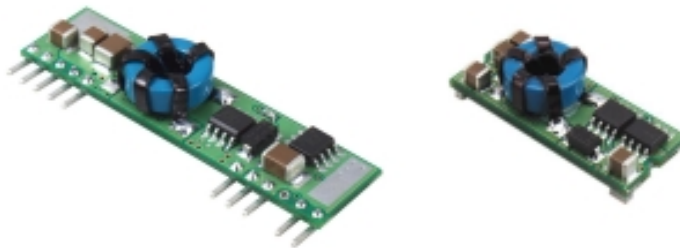

ALUS
E195564

- DC/DC non-isolated regulator modules
- Industry standard pinning
- Continuous short circuit proof
- High efficiency up to 95%
- Very low output ripple and noise
- Over temperature protection
- Single-in-line footprint or surface mounted
- External output voltage adjust
- Remote on/off control
- DC/DC Regler ohne galvanische Trennung
- Industriestandard pinning
- Dauerkurzschlussfest
- Hoher Wirkungsgrad von bis zu 95%
- Sehr gute Werte von Rippel und Noise
- Übertemperaturschutz
- Single-in-line footprint oder surface mounted
- Ext. Ausgangsspannungsabgleich
- Inhibit
- Module convertisseur DC/DC sans séparation galvanique
- Pinning standard industriel
- Protection contre courts-circuits permanents
- Degré d'efficacité jusqu'à 95%
- Ondulation résiduelle de sortie très faible
- Protection de température trop élevée
- Single-in-line footprint ou SMD
- Ajustement externe de la tension sortie

Product range

Typenübersicht

Sommaire des types

PART NUMBER	INPUT VOLTAGE		INPUT CURRENT		OUTPUT		EFFICIENCY
	Nominal	Range	max. @ full load	No Load	Voltage	Current	Typical
ERS05-1V010*	5 VDC	3...5.5 VDC	2.35 A	50 mA	1.0 VDC	10 A	85%
ERS05-1V212*	5 VDC	3...5.5 VDC	2.79 A	50 mA	1.2 VDC	10 A	86%
ERS05-1V515*	5 VDC	3...5.5 VDC	3.41 A	50 mA	1.5 VDC	10 A	88%
ERS05-1V818*	5 VDC	3...5.5 VDC	4.00 A	50 mA	1.8 VDC	10 A	90%
ERS05-2V020*	5 VDC	3...5.5 VDC	4.40 A	60 mA	2.0 VDC	10 A	91%
ERS05-2V525*	5 VDC	3...5.5 VDC	5.38 A	60 mA	2.5 VDC	10 A	93%
ERS05-3V333*	5 VDC	4.5...5.5 VDC	6.95 A	60 mA	3.3 VDC	10 A	95%
ERS12-1V010*	12 VDC	9...14 VDC	0.99 A	50 mA	1.0 VDC	10 A	84%
ERS12-1V212*	12 VDC	9...14 VDC	1.16 A	50 mA	1.2 VDC	10 A	86%
ERS12-1V515*	12 VDC	9...14 VDC	1.40 A	50 mA	1.5 VDC	10 A	89%
ERS12-1V818*	12 VDC	9...14 VDC	1.67 A	50 mA	1.8 VDC	10 A	90%
ERS12-2V020*	12 VDC	9...14 VDC	1.83 A	60 mA	2.0 VDC	10 A	91%
ERS12-2V525*	12 VDC	9...14 VDC	2.26 A	60 mA	2.5 VDC	10 A	92%
ERS12-3V333*	12 VDC	9...14 VDC	2.96 A	70 mA	3.3 VDC	10 A	93%
ERS12-0550*	12 VDC	9...14 VDC	4.39 A	70 mA	5.0 VDC	10 A	95%
ERS12-0550A*	12 VDC	8.3...14 VDC	2.96 A	70 mA	0.75..5 VDC	10 A	93%(3.3V)

* Add -S for SMD version

ERS 05 - 3V3 33 x y - S

Product Series

Nominal Input Voltage

Nominal Output Voltage
(3V3 = 3.3V)

Output Power in Watts

blank = SIL-11 pinning

S = SMD (surface mounted)

blank = positive logic inhibit on/off

N = negative logic inhibit on/off

blank = +5%,-10%output voltage adjust

A = 0.75-5Vdc output voltage trimming
(only ERS12-0550A*)

Specifications

Spezifikationen

Spécifications

All values refer to an ambient temperature of 25°C and nominal rated values where nothing else is specified

INPUT SPECIFICATIONS

Characteristics		Conditions	min	typ	max	unit
U_{in}	Input voltage	$T_A < T_{Amax}$	see "product range", page 1			Vdc
I_{nl}	No load current	$I_{out} = 0; U_{in} > U_{in off}$	see "product range", page 1			mA
$U_{in off}$	Under voltage lockout ($U_{in nom} = 5Vdc$)	Power up ($U_{in nom} = 5Vdc$)		2.8		Vdc
		Power down ($U_{in nom} = 5Vdc$)		2.7		Vdc
	Under voltage lockout ($U_{in nom} = 12Vdc$)	Power up ($U_{in nom} = 12Vdc$)		8.0		Vdc
		Power down ($U_{in nom} = 12Vdc$)		7.7		Vdc
$I_{in max}$	Full load input current	$P_{out} = P_{max}$	see "product range", page 1			A
	Reversed polarity protection		none			
	Inhibit on/off control (positive logic)	On (open circuit or open collector referenced to $-U_{in}$)			+Vin	Vdc
		Off (open collector referenced to $-U_{in}$)			< 0.4	Vdc
	Inhibit on/off control (negative logic; add suffix "N" to part number) see "Inhibit on/off control", page 9	On (open circuit or open collector referenced to $-U_{in}$)			open circuit or < 0.4	Vdc
		Off (open collector referenced to $-U_{in}$)	2.8		+Vin	Vdc

Note: it is recommended to put a 100uF capacitor (ESR<100mOhm) in parallel close to the input to reduce the input ripple voltage (EMC conducted).

OUTPUT SPECIFICATIONS

Characteristics		Conditions	min	typ	max	unit
U_{acc}	Output voltage accuracy	of nominal output voltage			±1.5	% U_{out}
	Line regulation	$I_{out} = I_{out nom}$			±0.2	% U_{out}
	Load regulation	0% load up to 100% load			±0.5	% U_{out}
t_r	Load transient recovery time	10% to 100% step load change		700		us
	Load transient error band			±6		% U_{out}
t_s	Start-up time	Connection of input and until $U_{out} = 90\% U_{out nom}$		7		ms
T_{coeff}	Temperature coefficient			±0.03		%/°C
$U_{out trim}$	Output voltage adjustment see "External output voltage trim", page 9.	All models except models listed below		±10		% $U_{out nom}$
		ERS12-0550	-5		+10	% $U_{out nom}$
		ERS12-0550A	0.75		5.0	Vdc

Characteristics		Conditions	min	typ	max	unit
$U_{r,n}$	Output ripple & noise ²⁾	Measured with 10uF tantalum capacitor and 1uF ceramic capacitor across the output			50	mVpp
C_{max}	Output capacitance	low ESR			10	mF
$I_{out,max}$	Output current limit threshold	see current limit chart, page 4			150	% $I_{out,nom}$
	Output short circuit characteristic	see short circuit protection graph, page 4	hiccup mode			
	Output short circuit protection			continuous		

2) Note: it is recommended to put 10uF tantalum capacitor and 1uF ceramic capacitor across the output to reduce ripple & noise.

GENERAL SPECIFICATIONS

Characteristics		Conditions	min	typ	max	unit
U_{iso}	Isolation voltage	input/output, input/case, output/case		none		Vdc
R_{iso}	Isolation resistance	Input to output		none		MOhm
f_s	Switching frequency	Fixed	270	300	330	kHz
	Approvals	File number E195564		UL / cUL1950		
	Case material		Open Frame			
	Weight			7		g
	Pinning	see "case" page 8				
	Dimensions	LxWxH, see "case" page 8	50.8 x 8.3 x 12.7 (13.0)			mm
	Soldering temperature (SIL-11)	peak temperature, maximum 10s preheating: temperature ramp 4°C/sec to 160°C, 25mm/sec.			260+/-5	°C
	Soldering temperature (SMD)	Reflow soldering	see "Soldering", page 10			°C

EMC SPECIFICATIONS

Characteristics		Conditions	min	typ	max	unit
	EMC conducted	EN 55022, see "EMC information" page 4	t.b.d.			

ENVIRONMENTAL SPECIFICATIONS

Characteristics		Conditions	min	typ	max	unit
	Vibration (sinusoidal)	Frequency 10-500 / 500-10 Hz Swep 2 / axis Duration 6 min / axis non operating	10			G
	Shock (half sinus)	Number of pulses 3 in 6 directions Pulse duration 11ms Wave form half sine wave non operating	40			G
T_A	Operating temperatures	Ambient temperature, see also "Derating" page 6	-40		+85	°C
	Storage temperatures	Ambient temperature	-55		+125	°C
	Thermal shutdown	Temperature at MOSFET (Q1), pin 6, see "Thermal shutdown", page 10	110	120	130	°C

EMC information conducted, ERS05-3V333:

EMC tests conducted at full load. Input capacity of 100uF in parallell was used.

For further EMC requirements, please contact your local distributor / representative or contact Fabrimex directly.

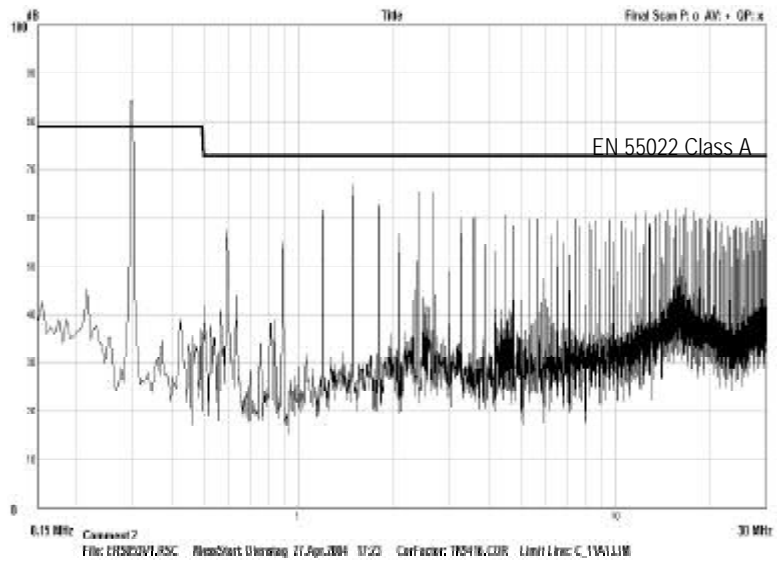

Typical characteristics

Efficiency $U_{out} = 3.3V$ (typical)

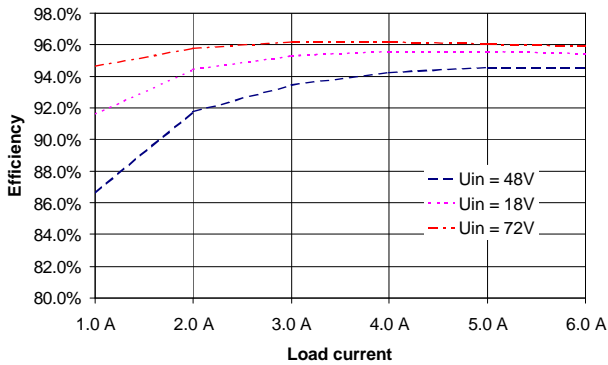

Efficiency $U_{out} = 1.8V$ (typical)

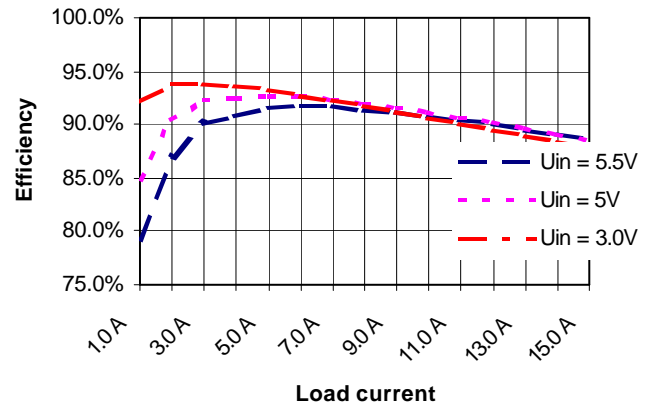

Short circuit protection (typical)

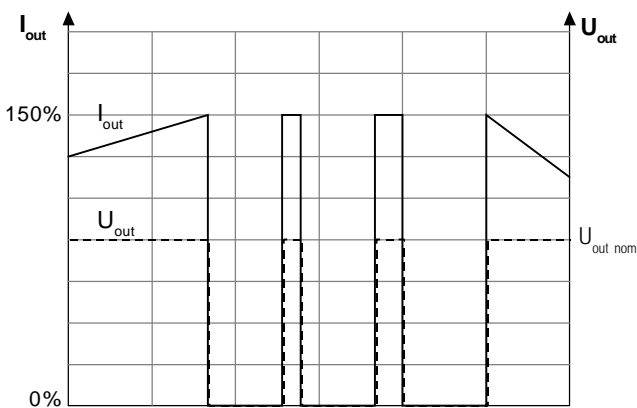

Current limit characteristic (typical)

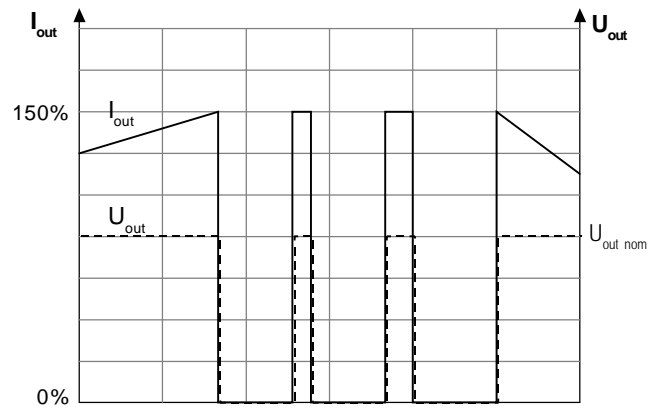

Derating ERS 10A Series, SIL-11

The operating ambient temperature range of ERS 10A series is -40°C to $+85^{\circ}\text{C}$. When operating the ERS series, proper derating or cooling is needed. The following curves are the derating curves of ERS 10A without heat sink. Please note that these are relative typical values in a test environment. Ambient temperature can not be exactly defined in an application.

Derating ERS05-xxxx (SIL-11) at $U_{in} = 3.3 \text{ Vdc}$:

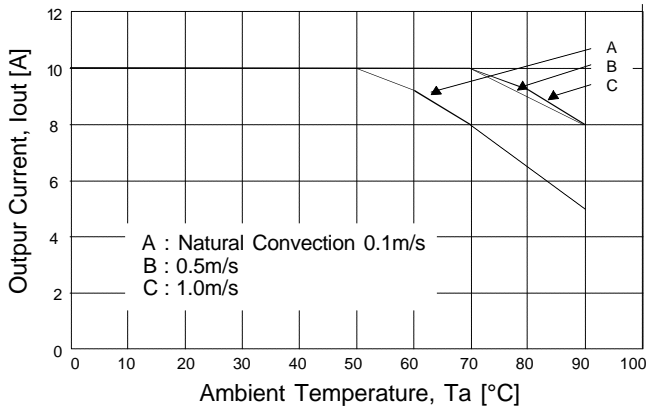

Derating ERS05-xxxx (SIL-11) at $U_{in} = 5 \text{ Vdc}$:

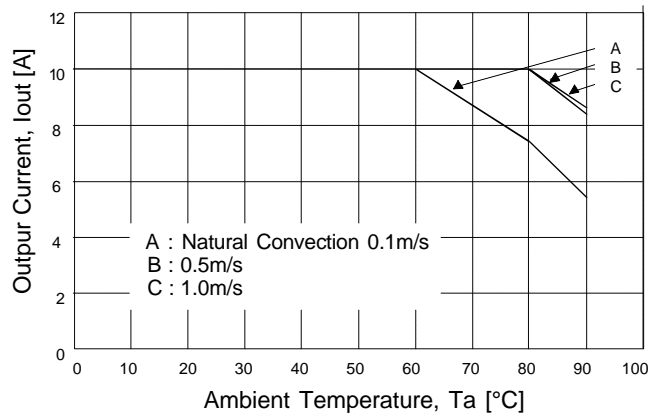

Derating ERS12-xxxx (SIL-11) at $U_{in} = 3.3 \text{ Vdc}$:

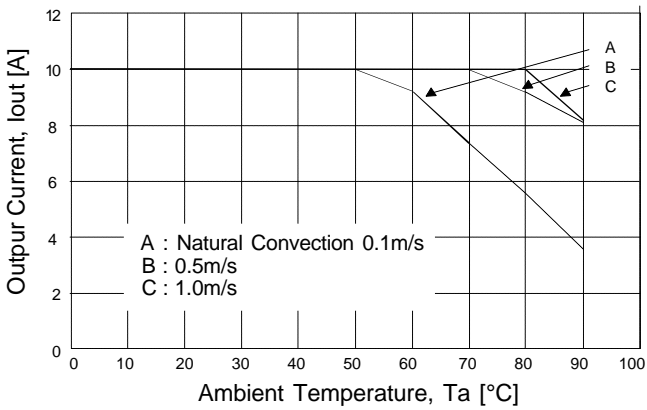

Derating ERS12-xxxx (SIL-11) at $U_{in} = 5 \text{ Vdc}$:

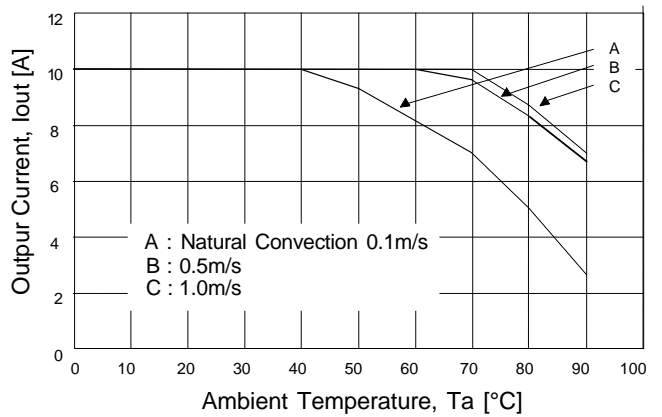

Remark:

Fabrimex recommends a free space of at least 5mm on each side of the regulator to ensure an efficient air flow.

For efficient cooling, the placement of the regulator must be considered so that the direction of the airflow is as shown:

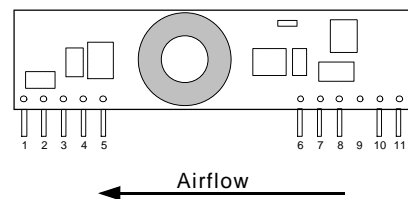

Derating ERS 10A Series, SMD

The operating ambient temperature range of ERS 10A series is -40°C to +85°C. When operating the ERS series, proper derating or cooling is needed. The following curves are the derating curves of ERS 10A without heat sink. Please note that these are relative typical values in a test environment. Ambient temperature can not be exactly defined in an application.

Derating ERS05-xxxx-S (SMD) at Uin =3.3 Vdc:

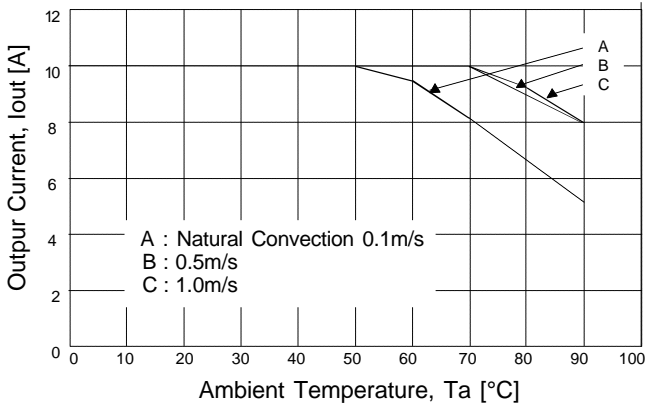

Derating ERS05-xxxx (SMD) at Uin =5 Vdc:

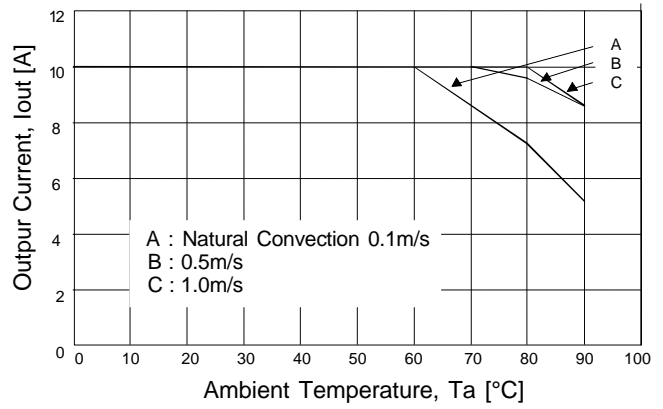

Derating ERS12-xxxx-S (SMD) at Uin =3.3 Vdc:

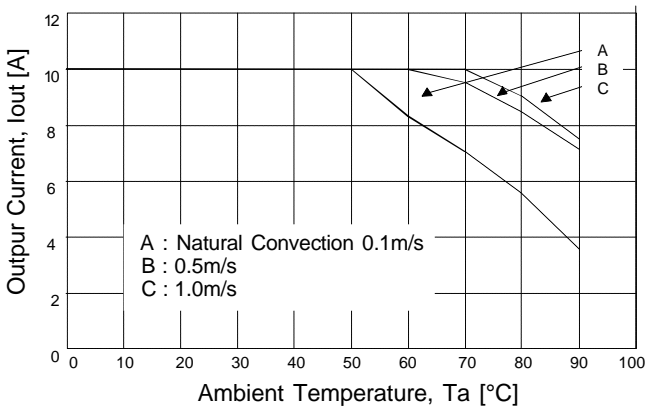

Derating ERS12-xxxx (SMD) at Uin =5 Vdc:

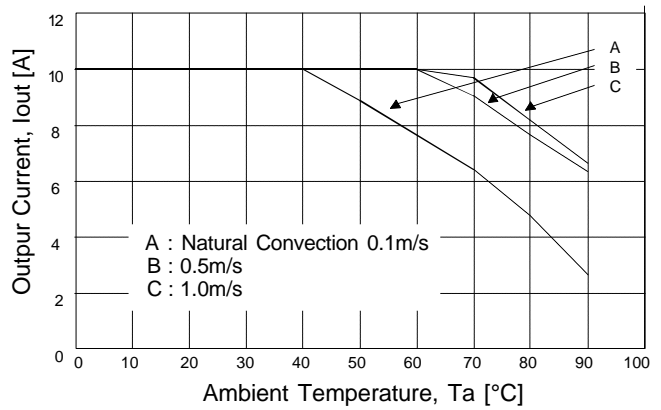

Remark:

Fabrimex recommends a free space of at least 5mm above the regulator to ensure an efficient air flow.

For efficient cooling, the placement of the regulator must be considered so that the direction of the airflow is as shown:

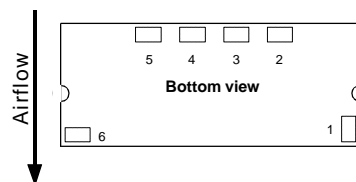

Case

Gehäuse

Boîtier

Normal tolerance 1/10 ±0.5 mm, 1/100 ±0.25 mm

ERS05-xxxx, $U_{in\ nom} = 5Vdc$ (SIL-11):

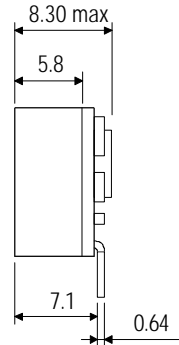
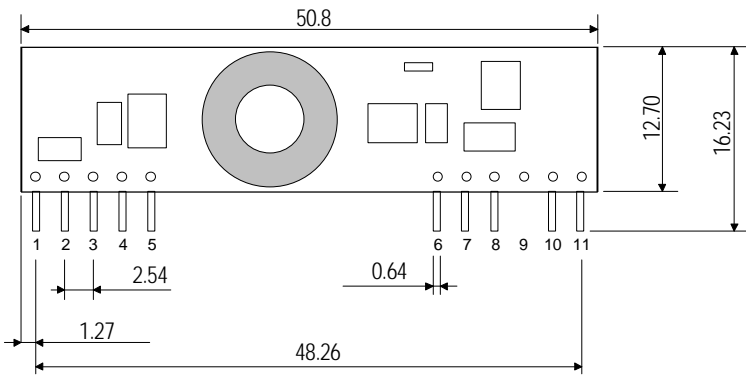

Pin	Function
1	+ Vout
2	+ Vout
3	+ sense
4	+ Vout
5	common
6	common
7	+ Vin
8	+ Vin
9	no pin
10	trim
11	on/off

ERS12-xxxx, $U_{in\ nom} = 12Vdc$ (SIL-11):

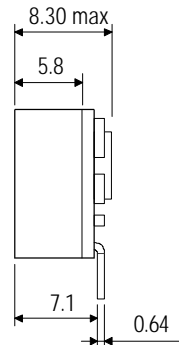
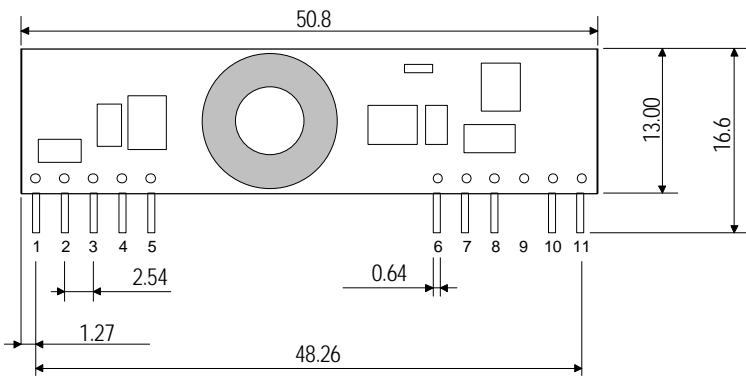

ERS 10A (SMD):

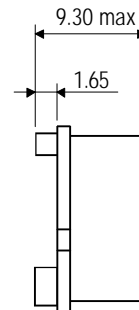
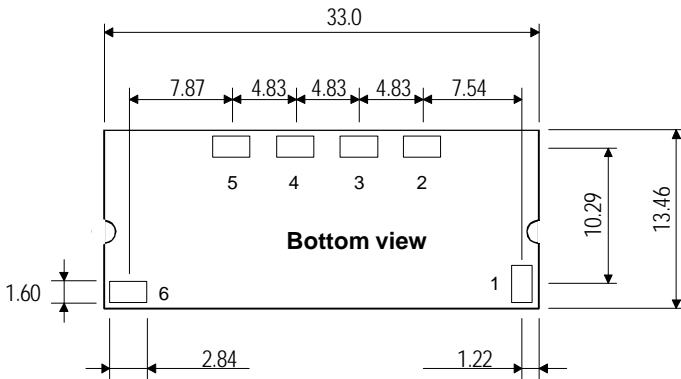

Pin	Function
1	on/off
2	+sense
3	trim
4	+ Vout
5	common
6	+ Vin

Packaging

Verpackung

Emballage

SMD Tape and Reel Dimensions

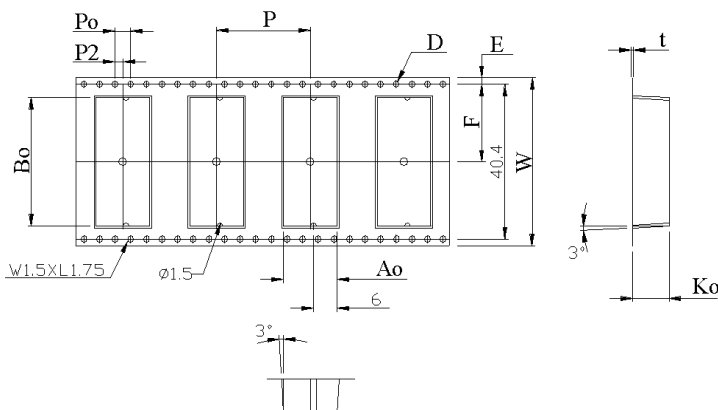

ITEM	SPEC
W	44.00 ^{+0.30} _{-0.30}
Ao	13.70 ^{+0.10} _{-0.10}
Bo	33.50 ^{+0.10} _{-0.10}
Ko	9.30 ^{+0.10} _{-0.10}
P	24.00 ^{+0.10} _{-0.10}
F	20.20 ^{+0.10} _{-0.10}
E	1.75 ^{+0.10} _{-0.10}
D	1.50 ^{+0.10} _{-0.05}
D1	2.00 ^{+0.25} _{-0.05}
Po	4.00 ^{+0.10} _{-0.10}
P2	2.00 ^{+0.10} _{-0.10}
t	0.40 ^{+0.05} _{-0.05}

The ERS 10A series topology is based on a non-isolated synchronous buck converter. In a typical pre-bias application the regulator does not draw any reverse current at start-up.

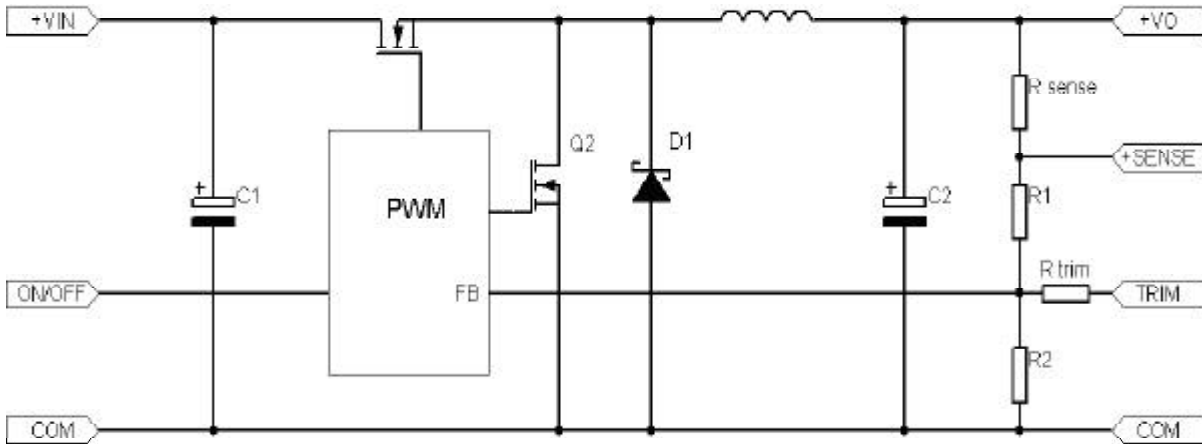

External output voltage trim

For the ERS05-xxxx, the trim function allows the user to adjust the output voltage between ±10% by connecting an external resistor either between the trim pin and the common pin (trim-up) or the trim pin and the +Uout pin (trim-down).

ERS05-xxxx:

Example trim-up / trim-down function:

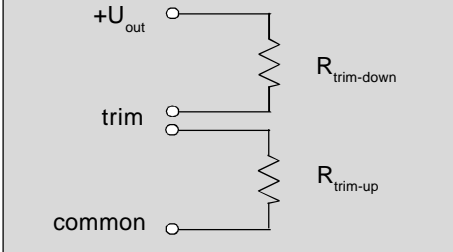

$U_{out-nom}$	$R_{trim-up}$	$R_{trim-down}$
1.0 Vdc	$R_{trim-up} = \frac{24.08}{(U_{out}-1)} - 30.1$ [kOhm]	$R_{trim-down} = \frac{30.1 \times (U_{out}-0.8)}{(1-U_{out})} - 30.1$ [kOhm]
1.2 Vdc	$R_{trim-up} = \frac{24.08}{(U_{out}-1.2)} - 59$ [kOhm]	$R_{trim-down} = \frac{30.1 \times (U_{out}-0.8)}{(1.2-U_{out})} - 59$ [kOhm]
1.5 Vdc	$R_{trim-up} = \frac{24.08}{(U_{out}-1.5)} - 100$ [kOhm]	$R_{trim-down} = \frac{30.1 \times (U_{out}-0.8)}{(1.5-U_{out})} - 100$ [kOhm]
1.8 Vdc	$R_{trim-up} = \frac{24.08}{(U_{out}-1.8)} - 100$ [kOhm]	$R_{trim-down} = \frac{30.1 \times (U_{out}-0.8)}{(1.8-U_{out})} - 100$ [kOhm]
2.0 Vdc	$R_{trim-up} = \frac{24.08}{(U_{out}-2.0)} - 100$ [kOhm]	$R_{trim-down} = \frac{30.1 \times (U_{out}-0.8)}{(2.0-U_{out})} - 100$ [kOhm]
2.5 Vdc	$R_{trim-up} = \frac{24.08}{(U_{out}-2.5)} - 78.7$ [kOhm]	$R_{trim-down} = \frac{30.1 \times (U_{out}-0.8)}{(2.5-U_{out})} - 78.7$ [kOhm]
3.3 Vdc	$R_{trim-up} = \frac{24.08}{(U_{out}-3.3)} - 59$ [kOhm]	$R_{trim-down} = \frac{30.1 \times (U_{out}-0.8)}{(3.3-U_{out})} - 59$ [kOhm]

The ERS12-0550A trim function requires the user to adjust the output voltage between 0.75Vdc and 5Vdc by connecting an external resistor between the trim pin and the +sense pin.

ERS12-0550A:

Application example trim function:

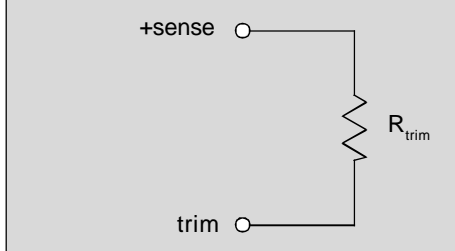

U_{out}	R_{trim}
0.75 Vdc	open
1.20 Vdc	22.33 kOhm
1.50 Vdc	13.0 kOhm
1.80 Vdc	9.0 kOhm
2.00 Vdc	7.4 kOhm
2.50 Vdc	5.0 kOhm
3.30 Vdc	3.12 kOhm
5.0 Vdc	1.47 kOhm

Inhibit on/off control

The ERS 10A allows the user to switch the module on and off electronically by inhibit on/off feature. If the control voltage exceeds 5.5Vdc then an external protective circuit has to be used similar to the following examples.

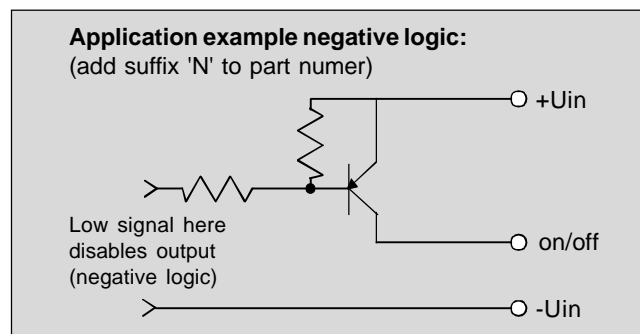
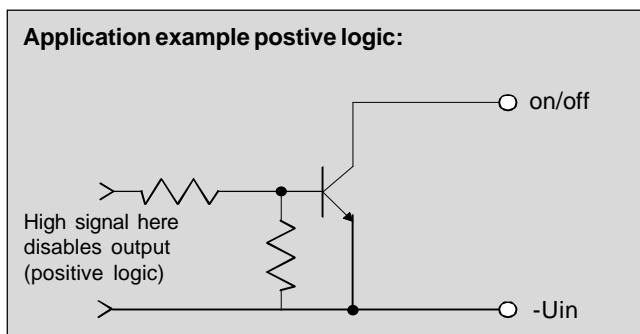

Remote sense

The ERS 10A allows the user to compensate any voltage drop between the regulator and the load by using the sense function. For proper operation the sense shall be connected as shown in the example, as close to the load as possible.

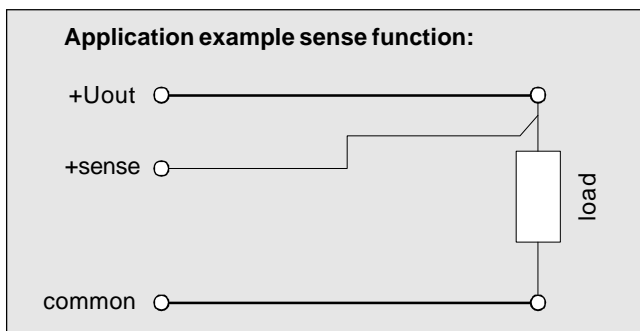

Thermal shutdown

The ERS 10A includes a temperature protection for safe operation. The temperature protection will shut down the regulator at typical 120°C at the pin 6 of the MOSFET's Q1 and Q2.

The regulator will automatically continue operation when the temperature at the pin(s) has dropped in the region of 40°C.

The temperature protection is a feature to enhance the safety in your application. Normal operation has to be designed so to stay within safe operation, temperature wise the pin temperature must stay below 110°C.

Frequent use of the temperature protection may result in damage of the regulator.

Please use the derating graphs to define the safe operating area in your application.

ERS 10A (SIL-11)

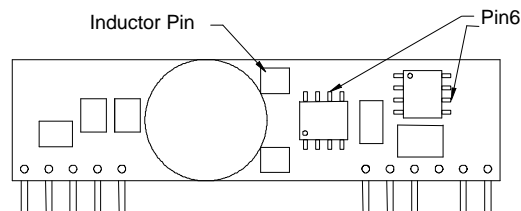

ERS 10A (SMD)

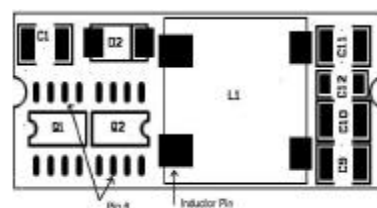

ERS 10A (SIL-11), wave soldering:

Peak temperature: 260°C ±5°C
 Peak duration: 10sec
 Temperature ramp: 4°C/sec to 160°C
 Feed rate: 25mm/sec

ERS 10A (SMD), reflow soldering:

The following reflow profile is an example for a SMD hot air reflow.

Peak temperature: 220°C
 Peak duration: 10sec

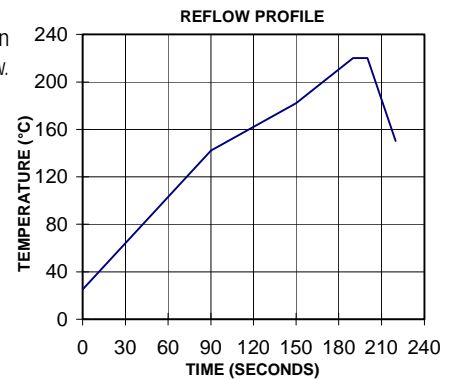

Notes

Cleaning

The modules are cleanable with the today's known and in the electronics industry usually used products.

Due to the different cleaning processes and new available products, we highly recommend to do a compatibility test when using the converters the first time.

Notice: All statements, technical information, and recommendations related to FABRIMEX's products are based on information believed to be reliable, but the accuracy or completeness thereof is not guaranteed. Before utilizing the product, the user should determine the suitability of the product for its intended use.

Waschen

Die Module sind waschbar mit den heute bekannten und in der Elektronikindustrie üblichen Reinigungsmitteln.

Bedingt durch die verschiedenen Reinigungsprozesse und neu auf den Markt kommende Mittel, raten wir dringend beim Ersteinsatz der Konverter eine Verträglichkeitsprüfung vorzunehmen.

Lavage

Les modules sont lavables avec les solvants couramment utilisés dans l'industrie électronique.

Dû aux différents processus de lavage et aux nouveaux détergents disponibles sur le marché, il est strictement recommandé de faire un test de compatibilité avant la première utilisation.

FABRIMEX
POWER SUPPLIES

Switzerland:
 FABRIMEX AG • Industriestrasse 4B • Volketswil
 Post Address: P.O.Box • CH-8603 Schwerzenbach
 Tel: +41-44-908 13 40 • Fax: +41-44-908 13 00
 Internet: <http://www.fabrimex.com>

Germany:
 CAC FABRIMEX GmbH • D-89543 Gerstetten
 Tel: 07323/ 950-0 • Fax: 07323/ 95050